

ACE 950

Modular Electric Dryers with Forced Hot Air

Main Application: DTG Digital Printing - Industrial production



code: **1390045**

Production: Water-based Digital Ink – A4 print size on T-shirt

3 minutes curing time: 180 pieces/h
 4 minutes curing time: 140 pieces/h
 5 minutes curing time: 110 pieces/h
 6 minutes curing time: 90 pieces/h

Data may change according to fabric material, drying area size and ink curing requirements.

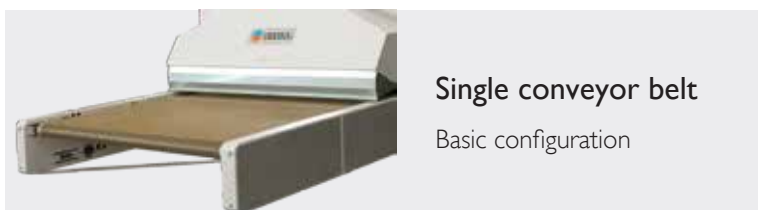
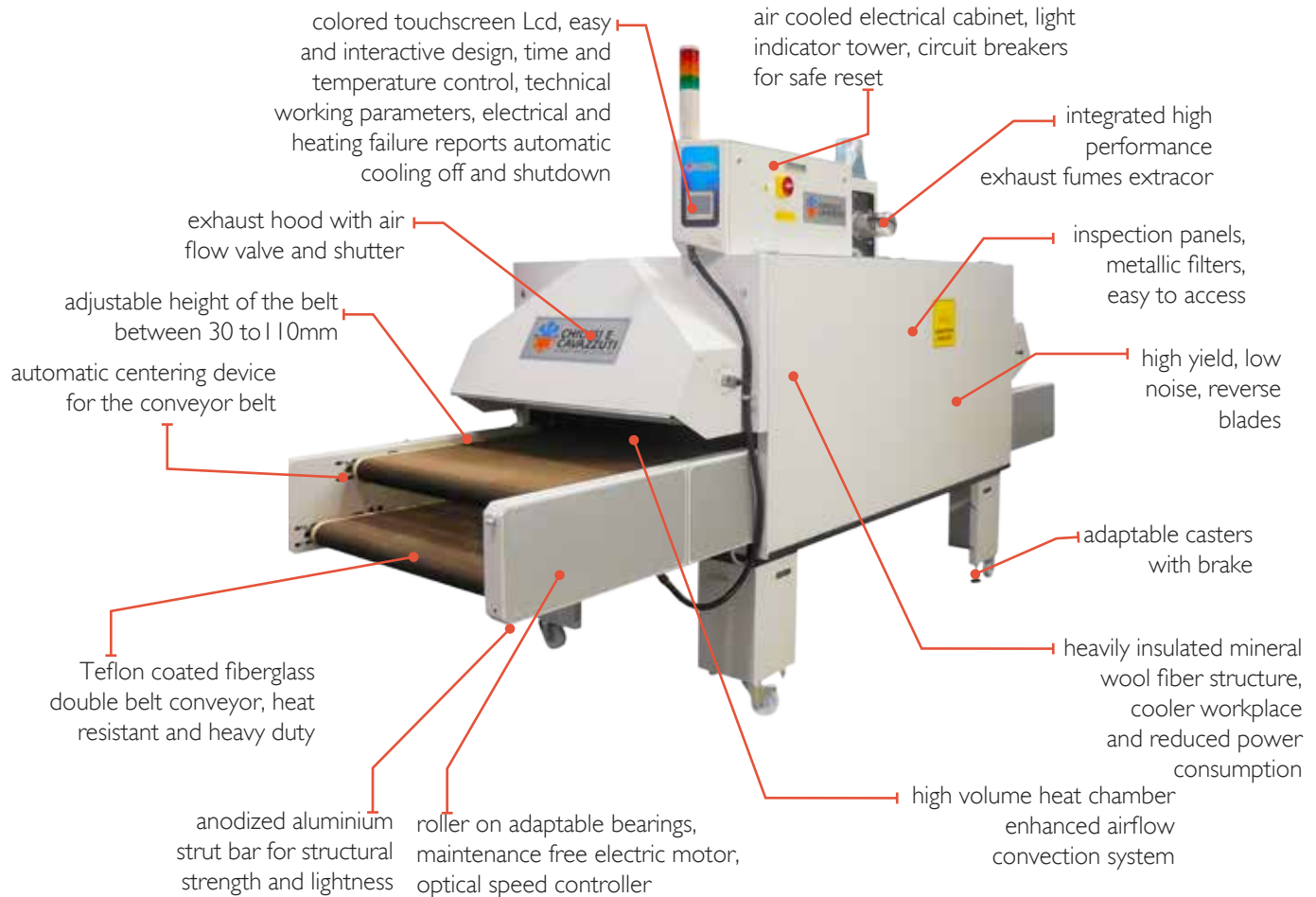

TECHNICAL DATA	ACE 950
Power Supply	400V 3P+PE (208V/230V 3P+PE optional)
Power Consumption ¹	14 kW - 20A
Max Temperature	180°C
Exhaust Specification	180 m ³ /h - Ø 150 mm
Tunnel Length	2000 mm
Belt Width [mm]	950 mm
Production ² (light-dark)	160 - 100 pieces/h
Dimension ³ (LxWxH)[mm]	3800 x 1250 x 2170 mm
Shipping Weight ³	650 kg

¹ Max Power consumption during first heating cycle. Working consumption is about 60% of max value, depending on environmental conditions.

² Production of L size T-shirts with A4 size DTG print - 4 minutes curing time for light garments - 6 minutes curing time for dark garments. Production data consider the loading side by side of 1 product for 600mm belt, 2 for 950mm, 3 for 1200mm and 4 for 1900mm belt.

³ Dimension and Weight can change accordingly to inlet/outlet extensions or installed optionals.



Hot
Air



DTG
Printing



Screen
Printing



Pad
Printing



Embroidery
Gauze

code: 1390045

FEATURES AND ADVANTAGES

- **Specifically designed to cure and dry digital printing on fabrics**, the massive advantage of this Dryer is the high volume of forced air circulation: this facilitates and accelerates the evaporation of water-based digital inks with unmatched results on the finished garment in medium-long drying process.
- **In the heat chamber the temperature is uniform and constant on both sides and the center**, adjusted by a precise thermostat and by a long lasting static relay control system; in this manner the temperature never exceeds the set value, preventing damage even to the most delicate fabrics.
- **Heavily insulated mineral-wool fiber structure** results in a cooler workplace and cool to the touch external skin. Remarkably it reduces both power consumption and heat dissipation.
- **The returning belt conveyor** allows the operator to work without having to change his position; the belt conveyor below works at lower temperatures; this improves curing quality and at the same time allows the operator to touch the printed garment without burning risk.
- **The air exchange is adjusted to discharge steam and promote high volume air circulation.** This enhanced airflow convection system is designed on purpose and employs high yield low noise reverse blades.
- **Speed, Time and Temperature control are processed digitally for precise and fast adjustments.** The automatic cooling off and shutdown can be set on demand to suit different working necessities; dryer technical parameters, real-time energy consumption and alarm notifications are clearly displayed.
- **Working height between 30 and 130mm**, in order to cure thick garments and objects and achieve a direct jet of air.
- **Every lateral panel is removable** to speed up maintenance operations and easily reach the filters.
- **Move the Dryer anywhere thanks to heavy duty casters with brakes.** Level it on any surface adjusting the threaded feet.

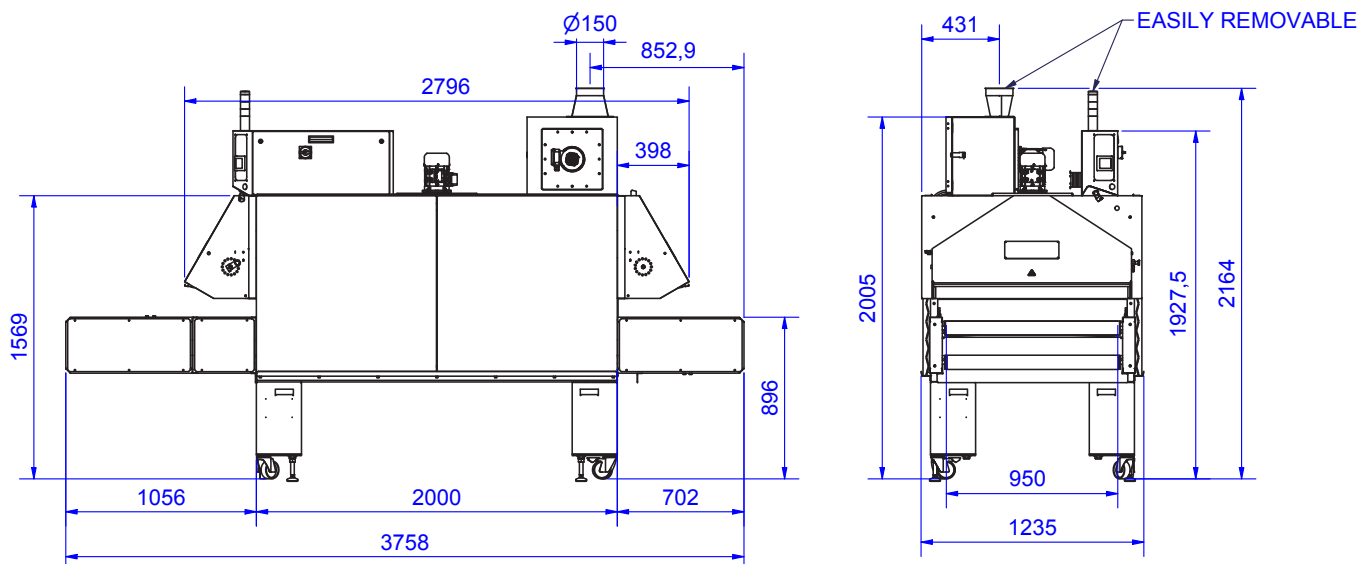

The data in this document was valid at the time of publishing, and is subject to change without notice. Chiossi e Cavazzuti srl reserves the right to modify its products and change their specifications at any time, without prior notice and further obligation. It is forbidden without prior authorization from Chiossi e Cavazzuti srl to copy, modify, alter, publish, distribute, sell or transfer this material. All rights reserved.